

---

## TTY6751 8 KEYS Capacitive Touch Key

●	<i>Descriptions of the Product</i> .....	2
●	<i>Features of the Product</i> .....	2
●	<i>Product Applications</i> .....	2
●	<i>Pin Diagram of Packaging</i> .....	3
●	<i>Pin Definition</i> .....	4
●	<i>AC / DC Characteristics</i> .....	5
	1 <i>Absolutely max. Ratings</i> .....	5
	2 <i>D.C. Characteristics</i> .....	5
	3 <i>A.C. Characteristics</i> .....	5
●	<i>Output Indicator</i> .....	6
●	<i>Descriptions of Function</i> .....	7
●	<i>Notes of Caution</i> .....	8
●	<i>Diagram of Application Circuits</i> .....	10
●	<i>Descriptions of Packaging</i> .....	11
●	<i>Information of Purchasing</i> .....	11
●	<i>History of Revisions</i> .....	11

- **Descriptions of the Product**

Provides 8 touch keys with binary code (BCD) output and the display of acknowledgment output of key pressing. The data after key pressing will remain until another key is pressed, which can be used to determine the acknowledgment status of key pressing. Provides low-power modes for products used in battery applications. Excellent performance in waterproof and anti-interference !

- **Features of the Product**

- Operating voltage range: 2.7V - 5.5V
- Operating current: 1.8mA (normal mode); 10 uA (sleep mode) @3.3V
- 8 touch control keys
- Enter the sleep mode without pressing the button for 4 seconds
- Provides binary coding (BCD) direct output interface (power on D2~D0/111)
- If the user leaves the operation after pressing a key, the output state will remain until another key is pressed
- Provides output for acknowledgment of effective key pressing. The output is at low voltage level when a key is pressed and at high voltage level when no key is pressed
- Sensitivity is adjustable through adjustment of the external capacitor connected to CAP pin. Sensitivity is higher with larger capacitance
- Waterproof and immersion proof. Key function is still effective even with water droplets covering the touch key panel

- **Product Applications**

- Suitable for use on all kinds of home appliances and entertainment products.

- **Pin Diagram of Packaging**

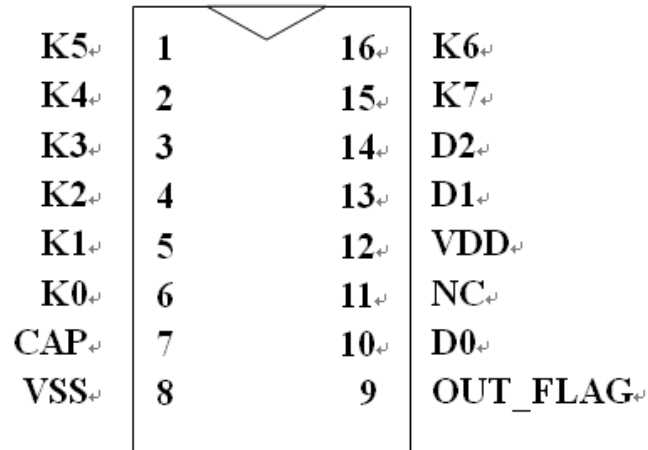

**TTP272-AOBN<sub>↙</sub>**  
**16-SOP-A<sub>↙</sub>**

- **Pin Definition**

Pin	Pin Name	Type	Descriptions of Function
1	K5	I	Pin of touch key, connected in series with resistors of 100-1000 ohms, to enable high resistance to interference and electrostatics
2	K4	I	Pin of touch key, connected in series with resistors of 100-1000 ohms, to enable high resistance to interference and electrostatics
3	K3	I	Pin of touch key, connected in series with resistors of 100-1000 ohms, to enable high resistance to interference and electrostatics
4	K2	I	Pin of touch key, connected in series with resistors of 100-1000 ohms, to enable high resistance to interference and electrostatics
5	K1	I	Pin of touch key, connected in series with resistors of 100-1000 ohms, to enable high resistance to interference and electrostatics
6	K0	I	Pin of touch key, connected in series with resistors of 100-1000 ohms, to enable high resistance to interference and electrostatics
7	CAP	--	Capacitor used must be made of NPO material or X7R material Range of use: 6,800pF-33,000pF, the larger the capacitance the higher the sensitivity
8	VSS	P	Negative terminal of power supply
9	OUT_FLAG	O	Acknowledgment of key pressing; low voltage level for effective key pressing
10	D0	O	Binary bit code output D0
11	NC	P	—
12	VDD	P	Positive terminal of power supply
13	D1	O	Binary bit code output D1
14	D2	O	Binary bit code output D2
15	K7	I	Pin of touch key, connected in series with resistors of 100-1000 ohms, to enable high resistance to interference and electrostatics
16	K6	I	Pin of touch key, connected in series with resistors of 100-1000 ohms, to enable high resistance to interference and electrostatics

- I COMS INPUT
- O COMS INPUT
- P POWER SUPPLY

- **AC / DC Characteristics**

1 Absolutely max. Ratings

ITEM	SYMBOL	RATING	UNIT
Operating Temperature	Top	-40- +85	°C
Storage Temperature	Tsto	-50- +125	°C
Supply Voltage	VDD	5.5	V
Voltage to input terminal	Vin	Vss-0.3 to Vdd+0.3	V

2 D.C. Characteristics

(Condition : Ta= 25 ± 3 °C , RH ≤ 65 % , VDD =+ 5V, VSS=0V)

Item	Symbol	Condition	Min.	Typ.	Max.	Unit
Operating voltage	VDD		2.7	5	5.5	V
Operating current	I <sub>OPR1</sub>	VDD=5V		3		mA
Input low voltage for input and I/O port	V <sub>IL1</sub>		0		0.3VDD	V
Input high voltage for input and I/O port	V <sub>IH1</sub>		0.7VDD		VDD	V
Output port source current	I <sub>OH1</sub>	V <sub>OH</sub> =0.9VDD, @5V		4		mA
Output port sink current	I <sub>OL1</sub>	V <sub>OL</sub> =0.1VDD, @5V		8		mA

3 A.C. Characteristics

Item	Symbol	Condition	Min.	Typ.	Max.	Unit
System clock	f <sub>SYS1</sub>	OSC @5v		4		MHz
Low Voltage Reset	V <sub>lvr</sub>		-	2.0	2.1	V

- **Output Indicator**

Provides 8 keys of capacitive touch control, with output in the format of binary coding (BCD).

The relation table is described below:

	Key	OUT_FLAG	D2	D1	D0	NOTE
	POWER ON	1	1	1	1	
K0	Touch	0	0	0	0	
	Release	1	Hold	Hold	Hold	
K1	Touch	0	0	0	1	
	Release	1	Hold	Hold	Hold	
K2	Touch	0	0	1	0	
	Release	1	Hold	Hold	Hold	
K3	Touch	0	0	1	1	
	Release	1	Hold	Hold	Hold	
K4	Touch	0	1	0	0	
	Release	1	Hold	Hold	Hold	
K5	Touch	0	1	0	1	
	Release	1	Hold	Hold	Hold	
K6	Touch	0	1	1	0	
	Release	1	Hold	Hold	Hold	
K7	Touch	0	1	1	1	
	Release	1	Hold	Hold	Hold	

Hold: maintain the output state of the last touch until the next time a key is pressed.

- **Descriptions of Function**

- 1 The state of the corresponding key output is within 50ms when the TTY6801 touch pad is pressed by a finger.
- 2 Output of the pressing of a single key is processed first. If K1 has acknowledged, other keys can only be acknowledged when K1 is released. Output of only one key can be sent out at the same time.
- 3 The idle-free function restores the system status if the effective output of pressed key remains on for over 10 seconds.
- 4 Function of environmental adaption changes the reference value according to the changes in ambient temperature and humidity to ensure normal key operation.
- 5 Capable of identifying water and finger touch. Key function is still effective even when immersed in water and with water droplets covering the touch pad. However, if a "water column" is formed on the touch pad, it has the equivalent effect of finger touch and will cause output from key press acknowledgment.
- 6 Please ground all unused keys to avoid false actions due to overly sensitive responses.

**● Notes of Caution**

1. Relation of Cs capacitance and sensitivity:
  - ① The smaller the Cs capacitance, the lower the touch sensitivity.
  - ② The larger the Cs capacitance, the higher the touch sensitivity.
  - ③ Capacitance of Cs ranges from 6800pF (682) to 33000pF (333).
  - ④ Capacitor materials with small temperature coefficient and stable capacitance are needed for measurement of Cs capacitance. As a result, capacitors made of NPO or X7R are needed.
2. In the power layout, one has to divide the design by circuit blocks, where the touch IC has independent wiring connected to the positive terminal of the power supply. If there is no independent wiring, connect the touch circuit first before forming connections with other circuits. The same rule applies to the ground part, where there is independent wiring connected to the ground of the power supply. Namely, star grounding is used. Such method can avoid interference by other circuits and significantly improve the stability of the touch circuit.
3. Single side PCB design. It is recommended to use a sensing spring as the touch pad. It is best to use a spring with a cap and a larger cap enables better sensitivity.
4. If the double side PCB design is used, the touch pad can be circular or square by design. The common size is 12mm x 12mm. The IC wiring should be arranged on the other side of the touch pad. Meanwhile, thinner wire should be used and do not create excessively long wiring.
5. The PCB and the external cover must be sealed together securely. Otherwise, the capacitor dielectric will change, which affects the capacitance measurement and leads to instability. It is recommended to apply nonconductive glue such as 3M HBM series acrylic between the cover and PAD.
6. The overall stray capacitance must be minimized to increase the sensitivity. The wiring area between the touch IC pins and touch pad is not grounded on either the front or back. However, touch areas in the area outside to the sides of PCB must be covered by ground wiring as fences to isolate the capacitive interference from the sides. Only capacitance changes on top of the touch pad are accepted. The ground wire must be away from the touch area by at least 2mm. The distance between touch pads also needs to be at least 2mm to prevent parallel wiring of different pads from getting too close. This way the stray capacitance between the touch PAD and ground can be minimized, which helps improve the sensitivity of the product.

7. The principle of capacitive touch sensing works with treating the finger as the conductor. When the finger approaches the touch pad, it will increase the grounding paths and increase the stray capacitance. By checking the changes of capacitance, one can determine whether there is any finger touch. The change of the capacitance formed between the touch pad and finger is inversely proportional to the thickness of the touch cover and is proportional to the area of touch pad covered by the finger.
8. The cover material can also affect the sensitivity. Panels made of different materials have different dielectric constants. For example, the dielectric constant of glass is greater than that of organic glass (acrylic), which is greater than plastic. Given the same thickness, the larger the dielectric constant, the larger the capacitance formed between the finger and touch pad. Larger changes of capacitance in the measurement means easier press key acknowledgment and higher sensitivity.

## ● Diagram of Application Circuits

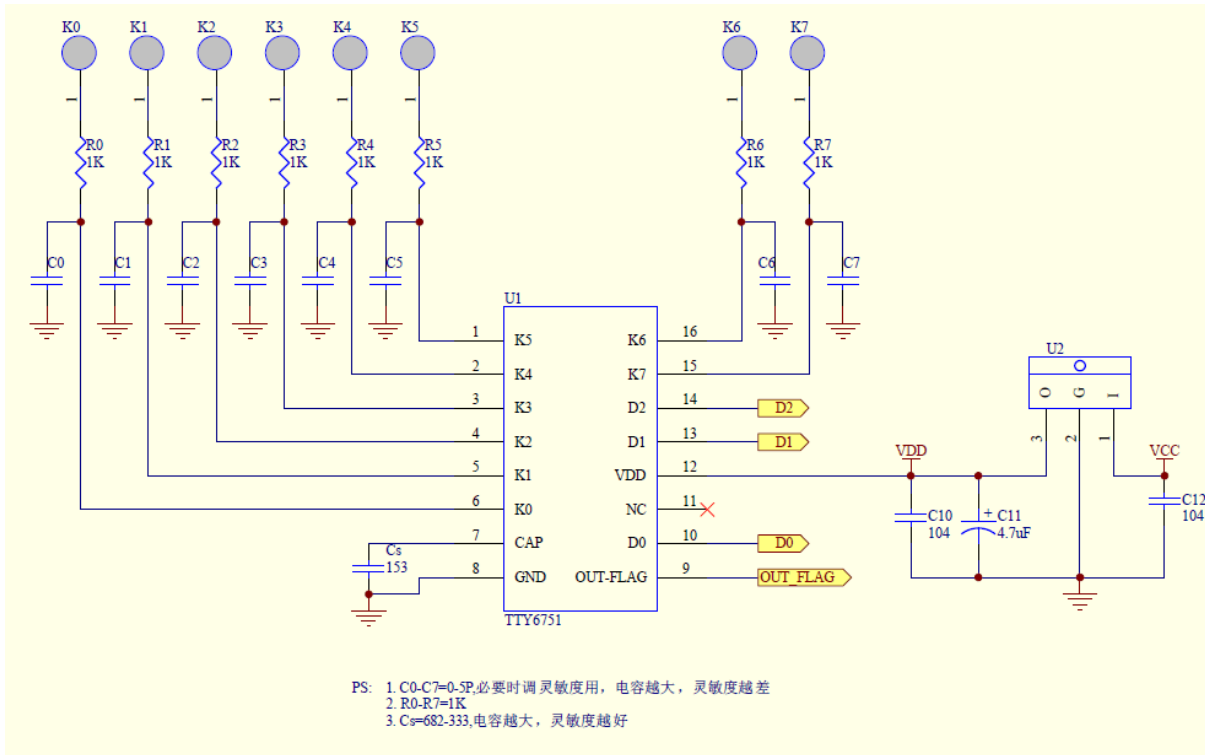

Relation of Cs external capacitor and acrylic thickness:

For a sensing spring with an iron cap and 12MM in diameter, the relation of acrylic thickness and CS capacitor is described below:

Acrylic thickness (mm)	CS	Sensitivity setting
1	682	16
2	103	16
3	153	16
4	223	16
5	223	16
10	333	16

This table is for reference only and subject to changes caused by PAD size and PCB layout.

- **Descriptions of Packaging**

(16-SOP)

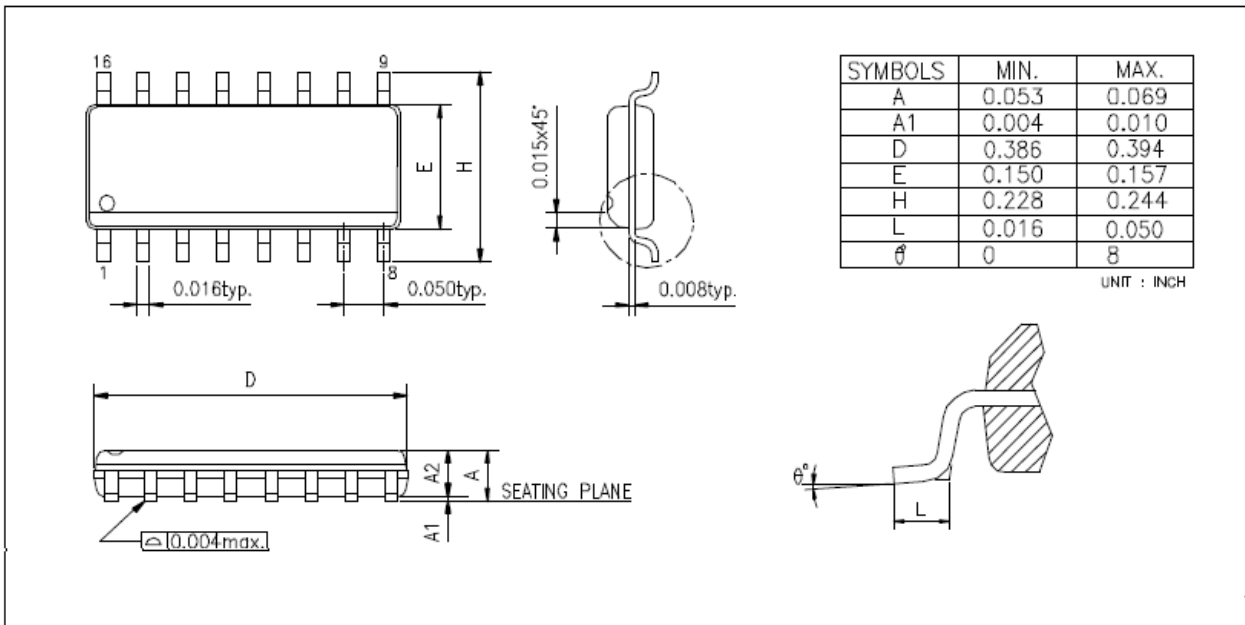

- **Information of Purchasing**

1. TTY6751
  - a. Packaging Model Number: TTP272-AOBN

- **History of Revisions**

1. 2019/05/07 - Original Version: Version: 1.00
  2. 2026/04/28 : Version: 1.10
    - a. Modify the chip operating temperature to: -40+85度