

1KEY Capacitive Touch Key

- *Descriptions of the Product*..... 2
- *Features of the Product*..... 2
- *Product Applications* 2
- *Pin Diagram of Packaging* 3
- *Pin Definition* 4
- *AC / DC Characteristics* 5
 - 1 *Absolute maximum ratings* 5
 - 2 *D.C. Characteristics*..... 5
 - 3 *A.C. Characteristics*..... 5
- *Output Indicator* 6
- *Descriptions of Function :* 6
- *Notes of Caution :* 7
- *Diagram of Application Circuits*..... 9
- *Descriptions of Packaging* 11
- *Information of Purchasing* 12
- *History of Revisions*..... 12

- **Descriptions of the Product**

1 touch control key is available with one-to-one direct output and excellent performance in waterproof and anti-interference.

- **Features of the Product**

- Operating voltage range: 2.7V - 5.5V
- Operating current: 1.8mA (normal mode); 10 uA (sleep mode) @3.3V
- 1 touch-sensitive button
- Automatically sleep when buttons are idle for four seconds.
- Keep the key pressed for more than 10 seconds to reset.
- Easy sensitivity adjustment achieved by adjusting the external capacitance at the CAP pin: the greater the capacitance, the higher the sensitivity.
- Provides output for acknowledgment of effective key pressing. The output is at low voltage level when a key is pressed and at high voltage level when no key is pressed.
- Waterproof and with effective judgment when the pad is covered by overflow or dew.

- **Product Applications**

- Suitable for use on all kinds of home appliances and entertainment products.

● Pin Diagram of Packaging

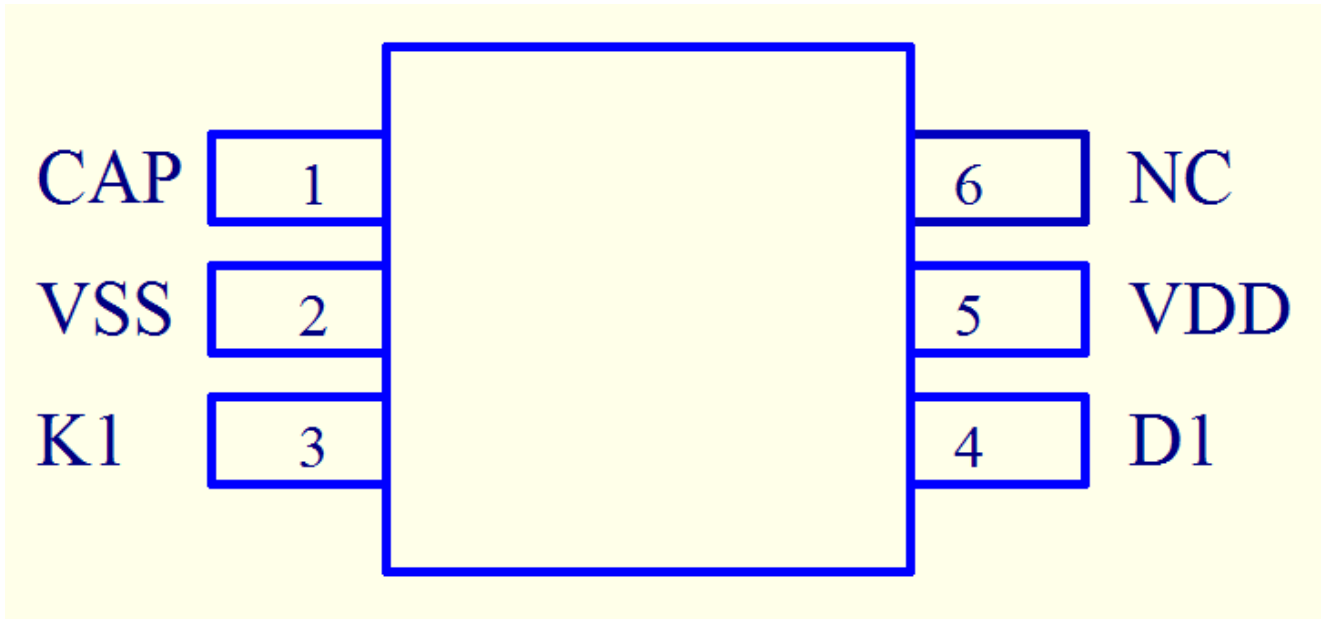

TTP277-CA6N
SOT23-6-A

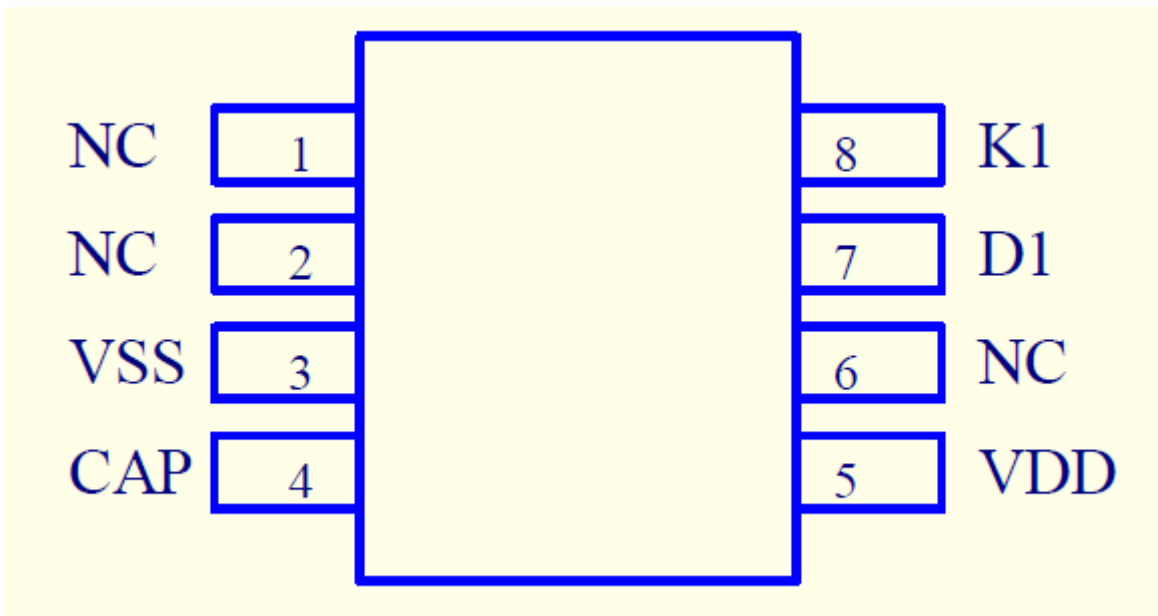

TTP277-EB8N
DFN8-A

● **Pin Definition**

SOT 23-6	DFN8	PIN NAME	I/O Type	Descriptions of Function
1	4	CAP	—	Capacitor used must be made of NPO material or X7R material Range of use: 6,800pF-33,000pF, the larger the capacitance the higher the sensitivity
2	3	VSS	P	Negative terminal of power supply, ground
3	8	K1	I	Pin of touch key, connected in series with resistors of 100-1000 ohms, to enable high resistance to interference and electrostatics.
4	7	D1	O	Pin of K1 status direct output output at high voltage level when there is no key pressed and output at low voltage level when the key is pressed.
5	5	VDD	P	Positive terminal of power supply
6	6	NC	—	
	1	NC	—	
	2	NC	—	

- I COMS INPUT
- O COMS OUTPUT
- P POWER SUPPLY

- **AC / DC Characteristics**

1 Absolute maximum ratings

Item	Symbol	Rating	Unit
Operating Temperature	Top	-40°C ~ +85°C	°C
Storage Temperature	Tsto	-50°C ~ +125°C	°C
Supply Voltate	VDD	5.5	V
Voltage to input terminal	Vin	Vss – 0.3 to Vdd + 0.3	V

2 D.C. Characteristics

(Condition : Ta= 25 ± 3 °C , RH ≤ 65 % , VDD =+ 5V , VSS=0V)

Parameter	Symbol	Test Conditions	Min	Typ	Max	Unit
Operating voltage	VDD		2.7	5	5.5	V
Operating current	I _{OPR1}	VDD=5V	-	3	-	mA
Input low voltage for input and I/O port	V _{IL1}		0	-	0.3V _D	V
Input high voltage for input and I/O port	V _{IH1}		0.7V _D	-	VDD	V
Output port source current	I _{OH1}	V _{OH} =0.9VDD, @5V	-	4	-	mA
Output port sink current	I _{OL1}	V _{OL} =0.1VDD, @5V	-	8	-	mA

3 A.C. Characteristics

Parameter	Symbol	Test Conditions	Min	Typ	Max	Unit
System clock	f _{SYS1}	OSC @5v	-	4	-	MHz
Low Voltage Reset	V _{lvr}		-	2.0	2.1	V

- **Output Indicator**

- Provides 1 key capacitive touch key, with one-to-one direct output.

- **Descriptions of Function:**

1. The state of the corresponding key output is within 50ms when the TTY675A touch pad is pressed by a finger.
2. The error prevention function restores the system status if the effective output of pressed key remains on for over 10 seconds. (T)
(Depending on the product application,FuncEdit can modify the parameters or cancel this function directly)

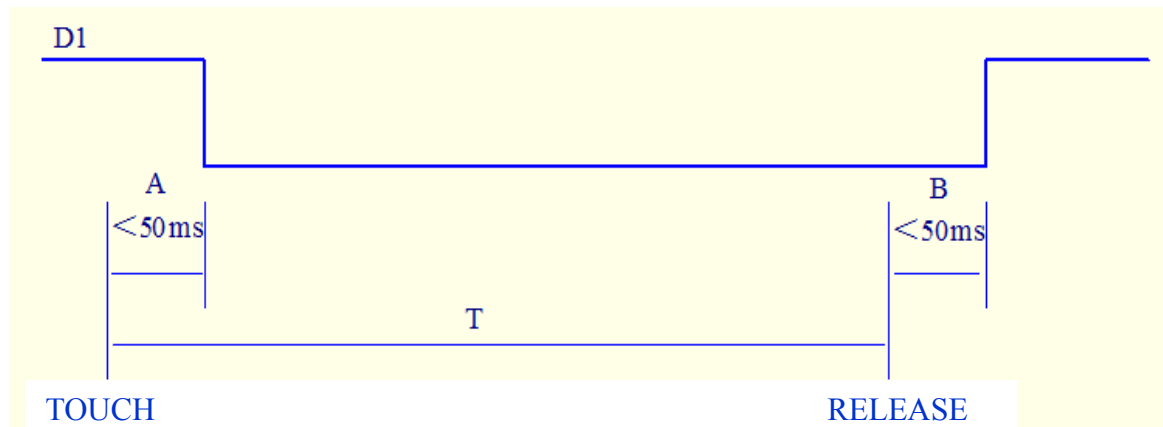

3. Function of environmental adaption changes the reference value according to the changes in ambient temperature and humidity to ensure normal key operation.
4. Capable of identifying water and finger touch. Key function is still effective even when a piece of water or water droplets covering the touch pad. However, if a "water column" is formed on the touch pad, it has the equivalent effect of finger touch and will cause output from key press acknowledgment.
5. The sensitivity of the touch key can be set by the program.

● **Notes of Caution:**

1. Correlations between capacitance (Cs) and sensitivity
 - (1) The smaller the Cs, the lower the sensitivity.
 - (2) The greater the Cs, the higher the sensitivity.
 - (3) Cs range : 6800pF (682) — 33000pF (333).
 - (4) When measuring capacitance by Cs, capacitor materials with a lower temperature change coefficient and high capacitance stability. Therefore, use only NPO or X7R capacitors.
2. In power layout, divide the circuit by block. A touch IC requires independent routing to positive power supply. When branch routing cannot be isolated, route the positive power supply to the touch IC before routing to other blocks. The same should apply to the grounding section to arrange independent branch routing to the ground of the power supply, i.e. star-earthed topology, to prevent the interference of other circuits in order to significantly enhance touch circuit stability.
3. In single-sided PCB design, touch-sensitive button springs are recommended for the pad, springs with a plate are the best choice for the highest sensitivity of the tough pad.
4. In double-sided PCB design, pads can be either circular or rectangular, with a recommended area of 12mm x 12mm. Cables linking the IC should be routed on the other side of the pad. Lower gauge cables are recommended to shorten routing.
5. The PCB must be tightly installed to the case. Loosened PCB-case installation will result in dielectric change to affect capacitance measurement and cause instability. Bonding the case and pad with non-conductive adhesive is recommended, such as acrylic glue, 3M HBM series.
6. To enhance sensitivity, the smaller the overall parasitic capacitance, the better the effect. Although neither the front nor the back of the routing area between the touch IC pins and the pad will be earthed, the area outside this area and around the PCB should be earthed to isolate this routing area to isolate capacitance interference around the pad like a wall for the circuit to receive only the capacitance above the pad. The ground should at least be 2mm away from the routing area, and the same space should be maintained between pads to maintain adequate spacing for the parallel leads of

individual pads, in order to reduce the parasitic capacitance between pads and ground to enhance sensitivity.

7. For capacitive touch buttons, fingers are considered as a conductor. When a finger approaches the pad, parasitic capacitance to the ground path increases for the IC to detect capacitance change and judge if the finger touches the pad. The capacitance change of pad-finger contact is opposite to that of pad-case contact, while the capacitance change of pad-finger contact and the area of touch are proportional.
8. Case materials also affect sensitivity due to dielectric difference, for example, glass > organic glass (acrylic) > plastics. At the same thickness, the greater the dielectric constant is, the greater the capacitance will be generated by a finger-pad contact. In measurement, the higher capacitance change is, the more easily a button is recognized, and the higher the sensitivity is.
9. Power supply must use LDO, if the voltage supply is drifting or rapid drift or shift, may cause sensitivity anomalies or misdetection.

● Diagram of Application Circuits

SOT23-6

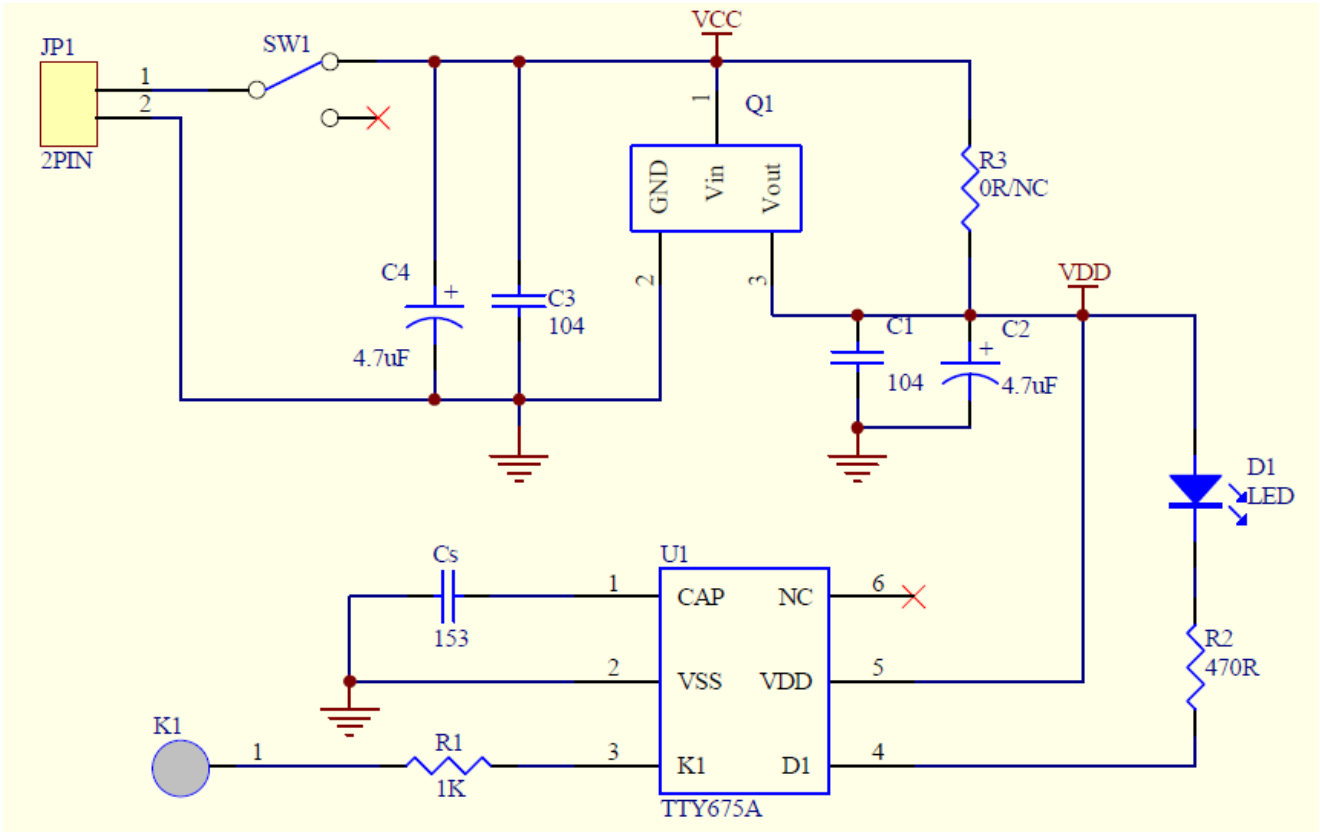

DFN8

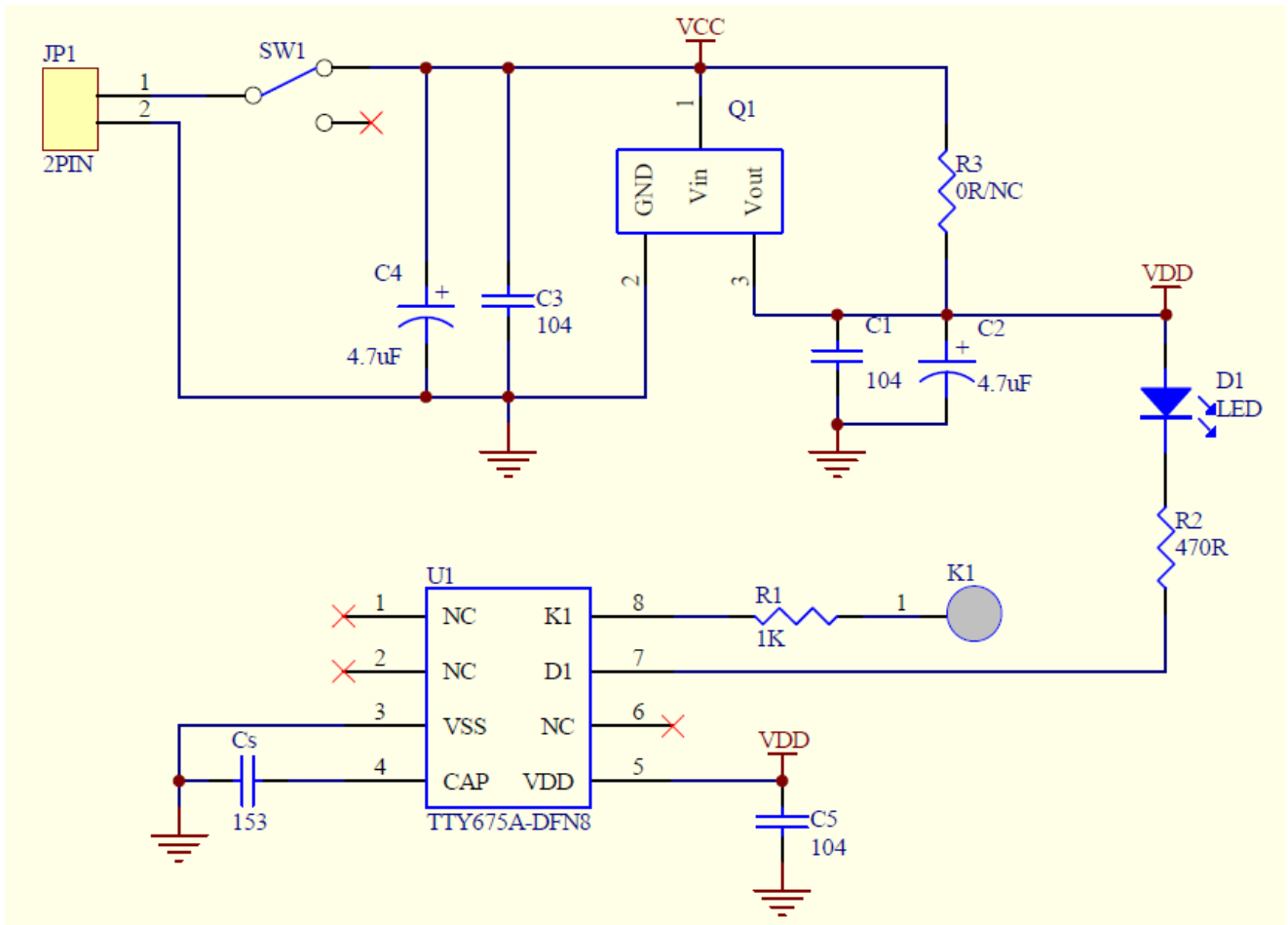

Relation of Cs external capacitor and acrylic thickness:

For a sensing spring with an iron cap and 12mm in diameter, the relation of acrylic thickness and CS capacitor is described below:

Acrylic thickness (mm)	CS	Sensitivity setting
1	682	16
2	103	16
3	153	16
4	223	16
5	223	16
10	333	16

This table is for reference only and subject to changes caused by PAD size and PCB layout

● **Descriptions of Packaging**

SOT23-6

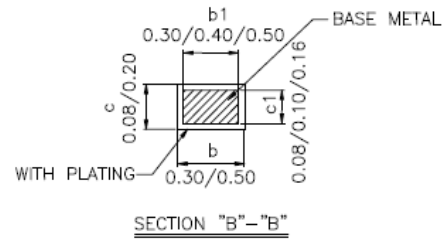
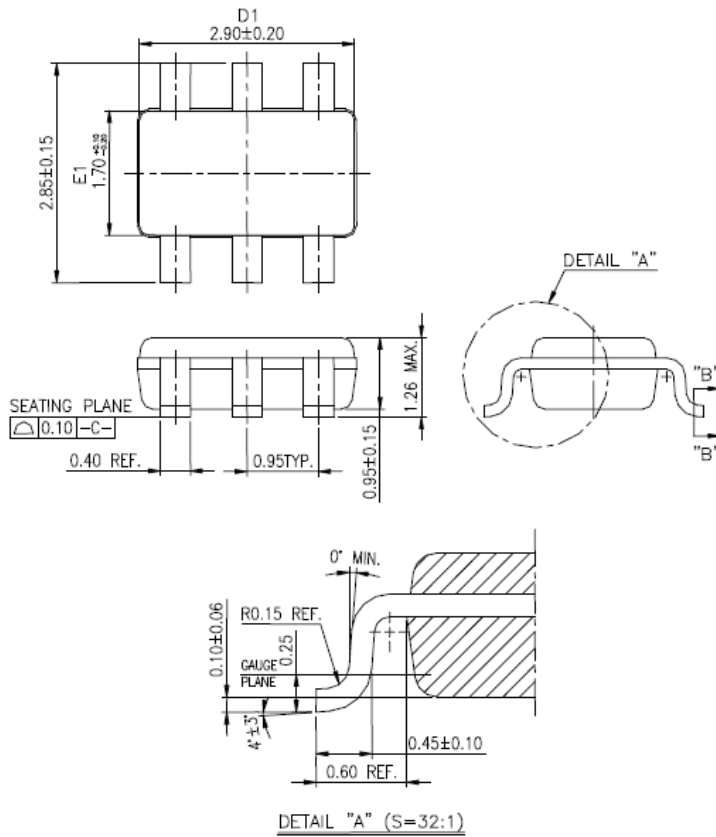

NOTES:

1. DIMENSION D1 & E1 DOES NOT INCLUDE MOLD PROTRUSION.
2. COPLANARITY OF ALL LEADS SHALL BE (BEFORE TEST) 0.1 MAX. FROM THE SEATING PLANE, UNLESS OTHERWISE SPECIFIED.
3. GENERAL PHYSICAL OUTLINE SPEC IS REFER TO TMC'S FINAL VISUAL INSPECTION SPEC UNLESS OTHERWISE SPECIFIED.

DFN8

TOP VIEW

SIDE VIEW

BOTTOM VIEW

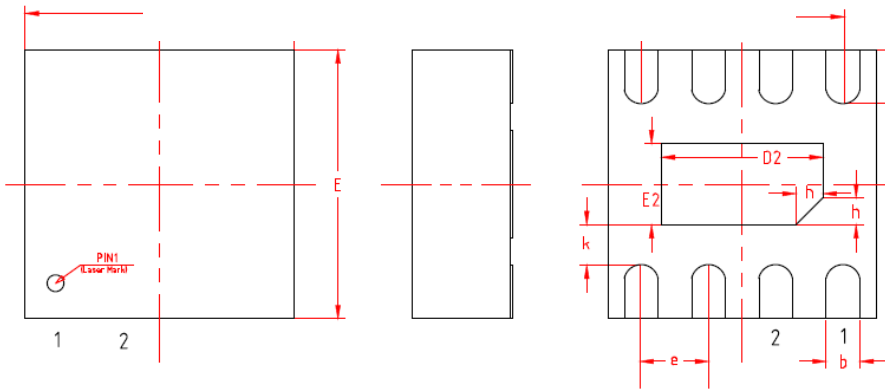

SIDE VIEW

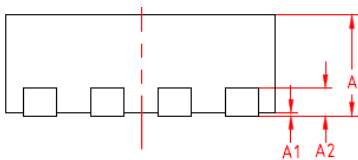

DIMENSION IN MM			
SYMBOL	MIN	NOMINAL	MAX
A	0.70	0.75	0.80
A1	-	0.02	0.05
A2	0.203 REF		
b	0.20	0.25	0.30
D	1.90	2.00	2.10
D2	1.10	1.20	1.30
E	1.90	2.00	2.10
E2	0.60	0.70	0.80
e	0.50 BSC		
K	0.25	0.30	0.35
L	0.30	0.35	0.40
h	0.15	0.20	0.25
Nd	1.50 BSC		

● Information of Purchasing

1. TTY675A
 - a. Packaging Model Number:
TTP277-CA6N
TTP277-EB8N

● History of Revisions

1. 2019/05/21 - Version: 1.0 Original version
2. 2019/11/21 - Version: 1.1 Add the "DFN8" package
3. 2021/10/13 - Version: 1.2 Modify the temperature range