

THERMOMETER SPECIFICATION

Contents :

- General Description :3
- Features :3
- Block Diagram :4
- Pad Description :5
- Electrical Parameter :6
- Function Description :7
-8
- LCD Pattern :9
- Application Circuit :10
- PAD Location :11
- Function Flow Chart :12
- Order Information :13
- Revise History :13

• General Description :

The **TCP316K-05** is an one-decimal electronic clinical thermometer IC. It can push switch to select the °C/°F mode.

• Features :

- ✧ Single 1.5V Battery Power-Supply
- ✧ Automatic Power-OFF Function
- ✧ Built-in Low-Voltage Detector Function
 - TCP316K-05A : 1.30 ± 0.05V**
 - TCP316K-05B : 1.25 ± 0.05V**
- ✧ Measurement Range(°C) : **32.0°C ~ 42.9°C**
- ✧ Measurement Range(°F) : **90.0°F ~ 109.9°F**
- ✧ Measurement Accuracy : ± 0.1°C (± 0.2°F)
- ✧ Resolution : 0.1°C (0.1°F)
- ✧ Highest Temperature Hold
- ✧ **Fever-Alarm Function** : Temperature \geq **37.8 °C (100.0 °F)**
- ✧ **Memory Function** : Display the Last Measuring Temperature.
- ✧ Bonding-Option for Stable Time Selection : **4s / 8s / 16s / 32s**
- ✧ Bonding-Option for Buzzer Alarm Frequency : **4KHz / 5.3KHz / 6.4KHz / 8KHz**
- ✧ Bonding-Option for °C and °F
- ✧ Bonding-Option for °C/°F Changeable or not Change Mode by Pushing-Switch
- ✧ When °C/°F Changeable Mode , Push ON/OFF Button to Select °C/°F
- ✧ **Build-in System-Frequency Oscillating Circuit**

• Block Diagram :

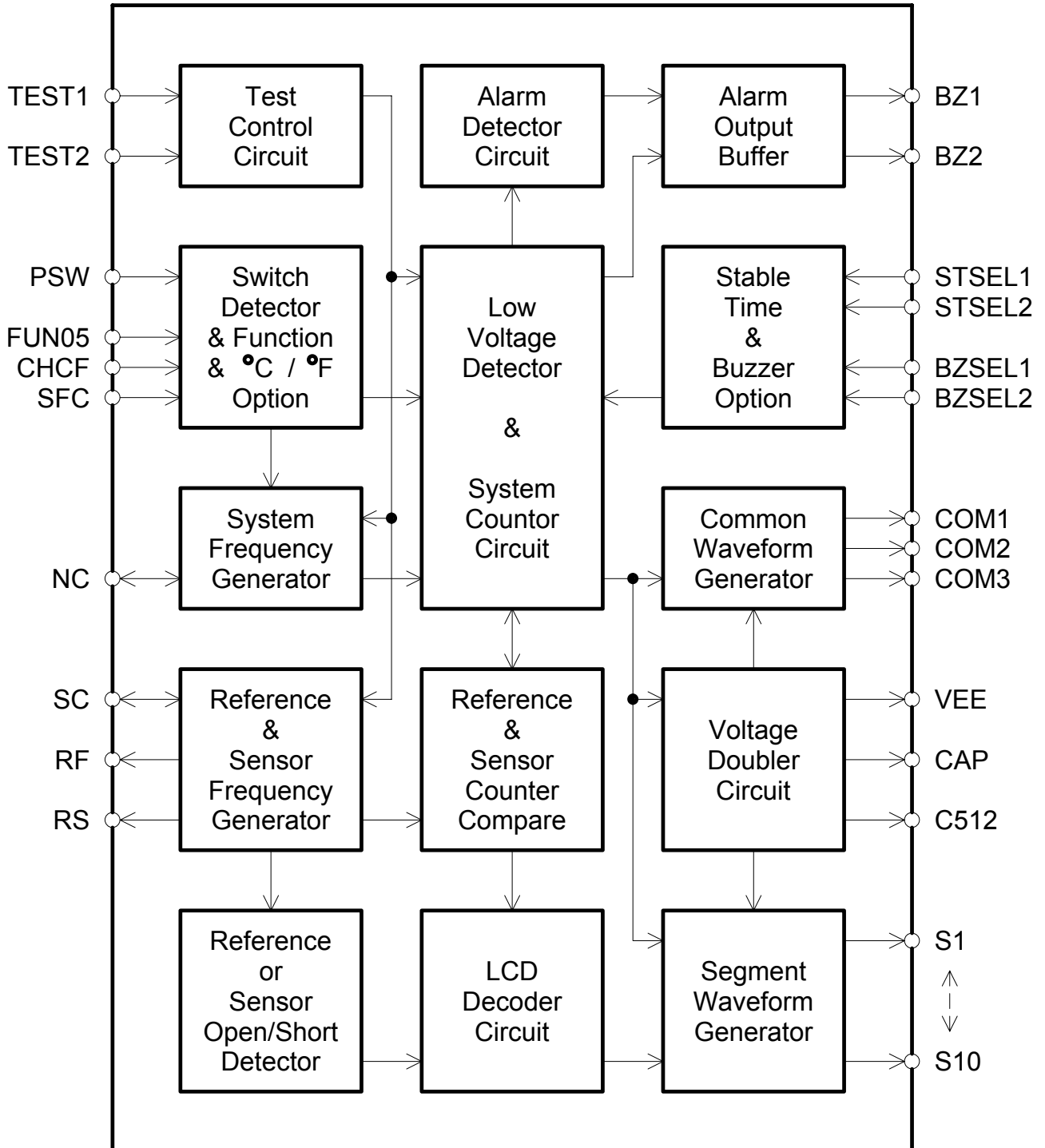

• Pad Description :

Pad No.	Pad Name	I/O	Description															
1~10	S1~S10	O	LCD Segment Driver , Connect to LCD															
11	VEE	O	Generated 3.0V Voltage(VDD=1.5V)															
12	CAP	O	For Positive Voltage Pumping															
13	C512	O	For Positive Voltage Pumping															
14	TEST1	I	Pull-Low Input Pad , Test-Pad for IC Test Only															
15	SFC	I	Bonding-Option for °C or °F Mode SFC= VDD or Open : °C (When °C/°F Change Mode , Power-ON is °C) SFC= VSS : °F (When °C/°F Change Mode , Power-ON is °F)															
16	CHCF	I	Bonding-Option for °C/°F Changeable or not Changeable Mode CHCF= VDD or Open : °C/°F Not Changeable Mode CHCF= VSS : °C/°F Changeable Mode															
17	VSS	P	Negative Power-Supply															
18	SC	I/O	Reference and Sensor Frequency															
19	RF	O	Connect to Reference Resistor															
20	RS	O	Connect to Sensor Resistor															
21	VDD	P	Positive Power-Supply															
22	PSW	I	Pull-High Input Pad , Push-Switch to Power-ON or Power-OFF															
23	TEST2	I	Pull-High Input Pad , for the Test of Production TEST2= VDD or Open : LCD Display the Highest Value TEST2= VSS : LCD Display the Real-Time Value															
24 25	BZSEL1 BZSEL2	I I	Pull-High Input Pad , Bonding-Option for Buzzer Output Frequency : <table border="1" style="width: 100%; border-collapse: collapse;"> <thead> <tr> <th>BZ Freq.</th> <th>BZSEL1</th> <th>BZSEL2</th> </tr> </thead> <tbody> <tr> <td>8.0KHz</td> <td>VDD or Open</td> <td>VDD or Open</td> </tr> <tr> <td>6.4KHz</td> <td>VSS</td> <td>VDD or Open</td> </tr> <tr> <td>5.3KHz</td> <td>VDD or Open</td> <td>VSS</td> </tr> <tr> <td>4.0KHz</td> <td>VSS</td> <td>VSS</td> </tr> </tbody> </table>	BZ Freq.	BZSEL1	BZSEL2	8.0KHz	VDD or Open	VDD or Open	6.4KHz	VSS	VDD or Open	5.3KHz	VDD or Open	VSS	4.0KHz	VSS	VSS
BZ Freq.	BZSEL1	BZSEL2																
8.0KHz	VDD or Open	VDD or Open																
6.4KHz	VSS	VDD or Open																
5.3KHz	VDD or Open	VSS																
4.0KHz	VSS	VSS																
26 27	STSEL1 STSEL2	I I	Pull-High Input Pad , Bonding-Option for Stable Time : <table border="1" style="width: 100%; border-collapse: collapse;"> <thead> <tr> <th>Stable Time</th> <th>STSEL1</th> <th>STSEL2</th> </tr> </thead> <tbody> <tr> <td>16 Sec</td> <td>VDD or Open</td> <td>VDD or Open</td> </tr> <tr> <td>4 Sec</td> <td>VSS</td> <td>VDD or Open</td> </tr> <tr> <td>8 Sec</td> <td>VDD or Open</td> <td>VSS</td> </tr> <tr> <td>32 Sec</td> <td>VSS</td> <td>VSS</td> </tr> </tbody> </table>	Stable Time	STSEL1	STSEL2	16 Sec	VDD or Open	VDD or Open	4 Sec	VSS	VDD or Open	8 Sec	VDD or Open	VSS	32 Sec	VSS	VSS
Stable Time	STSEL1	STSEL2																
16 Sec	VDD or Open	VDD or Open																
4 Sec	VSS	VDD or Open																
8 Sec	VDD or Open	VSS																
32 Sec	VSS	VSS																
28	FUN05	I	FUN05 must connect to VSS , For TCP316K-05 Function															
29	NC	X	No-Used															
30	BZ1	O	Buzzer Output Pad-1															
31	BZ2	O	Buzzer Output Pad-2															
32~34	COM1~COM3	O	LCD Common Driver , Connect to LCD															

• Electrical Parameter : [VDD=1.5V@25°C]

Description		Max.	Typical	Min.
1. Operating Voltage :		1.65V	1.50V	1.20V
2. Operating Average Current :		50uA	35uA	
3. Input Voltage :	VIL	Vss+0.3V		
	VIH			Vdd-0.3V
4. Output Voltage :	VOL	Vss+0.1V		
	VOH			Vdd-0.1V
5. Buzzer Driving Current : (Vds=1/2 Vdd)				1mA
6. Buzzer Sinking Current : (Vds=1/2 Vdd)				1mA
7. Pull-high Resistor : PSW Pad			1MΩ	
8. Pull-high Resistor : SFC 、CHCF 、 BZSEL1 、BZSEL2 、STSEL1 、STSEL2 Pad			500KΩ	
9. Pull-Low Resistor : TEST1 Pad			10KΩ	
10. Pull-High Resistor : TEST2 Pad			15KΩ	
11. Build-in System Oscillating-Frequency@1.5V : 262.144KHz ± 10%(262.144KHz / 8 = 32.768KHz)		288.358KHz	262.144KHz	235.929KHz
		36.044KHz	32.768KHz	29.491KHz

• Function Description :

- <1> Power SW : Push PSW switch to Power-ON or Power-OFF.
- <2> When Power-ON : Push the switch , a “ BI ” Sound for 0.125 Sec will be generated.
- A. The LCD display (188.8°M for **B-1** ; 188.8°C or 188.8°F for **B-2**) about **2 Sec**.
- B. After A :
- B-1. When CHCF=VDD or Open($^{\circ}\text{C}/^{\circ}\text{F}$ is not Changeable Mode by Pushing switch)**
The LCD Displays the Last Measuring Temperature and “ M ” Mark about **2 Sec** then Jump to the Step-C.
- B-2. When CHCF=VSS($^{\circ}\text{C}/^{\circ}\text{F}$ is Changeable Mode by Pushing switch)**
If Push-Switch Over **2 Sec** , the $^{\circ}\text{C}/^{\circ}\text{F}$ mode will be changed to another mode and only Display $^{\circ}\text{C}$ (or $^{\circ}\text{F}$) until Release-Switch. And then the LCD displays the Lo $^{\circ}\text{C}$ (or Lo $^{\circ}\text{F}$) and “ M ” Mark about **2 Sec** then Jump to the Step-C.
- C. After B :
- LCD Displays the Self-Test Temperature (**Normal 37.0°C / 98.6°F**) about **1 Sec**.
The $^{\circ}\text{C}/^{\circ}\text{F}$ Mark will start to Flash at the speed of **1Hz**
and Starts to Count the Stable-Time.
- D. After C :
- It will Start to Measure Temperature and the $^{\circ}\text{C}/^{\circ}\text{F}$ mark Flash at the speed of **1Hz**.
The LCD always Displays the Highest Measuring Temperature.
If it will Start to Measure Temperature and LCD Display always is not Change ; the Stable-Time is disabled , the $^{\circ}\text{C}/^{\circ}\text{F}$ mark always Flash at the speed of 1Hz , it will be Automatically Power-OFF after 8 min 40 sec($F_{\text{sys}}=32768\text{Hz}$)
- E. If the Temperature $< 32.0^{\circ}\text{C}$ (or 90.0°F) : the LCD Displays Lo $^{\circ}\text{C}$ (or Lo $^{\circ}\text{F}$).
- F. If the Temperature $\geq 43.0^{\circ}\text{C}$ (or 110.0°F) : the LCD Displays Hi $^{\circ}\text{C}$ (or Hi $^{\circ}\text{F}$).
- G. When Measuring : the LCD will always Display the Highest Temperature.
- H. If the Measure Temperature does not Change within the Stable-Time ,
the Measurement will be Over and the $^{\circ}\text{C} (^{\circ}\text{F})$ Mark Flash-Stop.
- I. When Measurement is Over and if the temperature $\geq 37.8^{\circ}\text{C}$ (100.0°F) ,
the Buzzer will Alarm “ BI—BI—BI——BI—BI—BI—— ” for 10 Sec , as follows :
BI—BI—BI——BI—
BI : 0.125 Sec
— : 0.125 Sec
—— : 0.375 Sec
If the temperature $< 37.8^{\circ}\text{C}$ (100.0°F) ,
the Buzzer will Alarms “ BI—BI—BI—BI— ” for 10 Sec , as follows :
BI—BI—
BI : 0.5 Sec
— : 0.5 Sec
- J. It will Automatically Power-OFF after measurement is Stable and the system is still on more than 8 min 40 sec($F_{\text{sys}}=32768\text{Hz}$).
- K. When Measurement is Over and the Beep-Sound is terminated ,
if the Temperature Rises within 8 min 40 sec , the Measurement will start again ,
but the $^{\circ}\text{C}$ ($^{\circ}\text{F}$) mark will Not Flash and the Buzzer will **Not Output** also.
- L. During BI-Sound is on 10 Sec and Delay 2 sec , the Temperature is not Measurement.

- <3> When Power-OFF : the Stand-By Current $\leq 0.5\mu A$.
- <4> Measurement to 0.1 degree at °C or °F.
- <5> Sensor use **503ET**.
- <6> Reference Resistor is the Value Sensor in **37.0 °C**.
- <7> When Battery Voltage is Low , the battery mark "■" will Flash at the speed of **1Hz**.
And the Measurement maybe not Accurate , it means thermometer must be changed Battery.
The Low Voltage Detect : (**TCP316K-05A : 1.30 ± 0.05V ; TCP316K-05B : 1.25 ± 0.05V**).
- <8> When TEST2-Pin is connected to VSS :
the LCD will Display the Real-Time Value not the highest value ,
in order to Adjust the reference resistance RF during the process of producing.
The LCD can be up or down changed , not always Display the Highest Value.
- <9> When Sensor circuit detect Error :
LCD only Display " Err " , it will not measure normally until the Error status Cancel.
- <10> The Frequency of Buzzer is selected By BZSEL1 and BZSEL2 Pads-Option.

Buzzer frequency	BZSEL1	BZSEL2
8.0 KHz	VDD or Open	VDD or Open
6.4 KHz	VSS	VDD or Open
5.3 KHz	VDD or Open	VSS
4.0 KHz	VSS	VSS

- <11> The 4 Kinds of Stable-Time are 4Sec/8Sec/16Sec/32Sec
to be selected by STSEL1 and STSEL2 Pads-Option.

Stable Time	STSEL1	STSEL2
16 Sec	VDD or Open	VDD or Open
4 Sec	VSS	VDD or Open
8 Sec	VDD or Open	VSS
32 Sec	VSS	VSS

- <12> °C/°F Power-ON Initial Function is used SFC Pad-Option.

Mode	SFC
°C	VDD or Open
°F	VSS

- <13> °C/°F Changeable or Not-Changeable Mode is used CHCF Pad-Option.

	CHCF
Not Changeable Mode	VDD or Open
Changeable Mode	VSS

Note : At Changeable Mode(CHCF=VSS) , Power ON Initial(**by Battery**) :
Maybe the LCD Display(°C or °F) will be Fail , it must be **Re-Power ON** Initial.

- <14> Thermometer others character is below:

Temperature range	32.0°C ~ 42.9°C	90.0°F ~ 109.9°F
Accuracy	±0.1 °C	±0.2 °F
Resolution	0.1 °C	0.1 °F

• LCD Pattern :

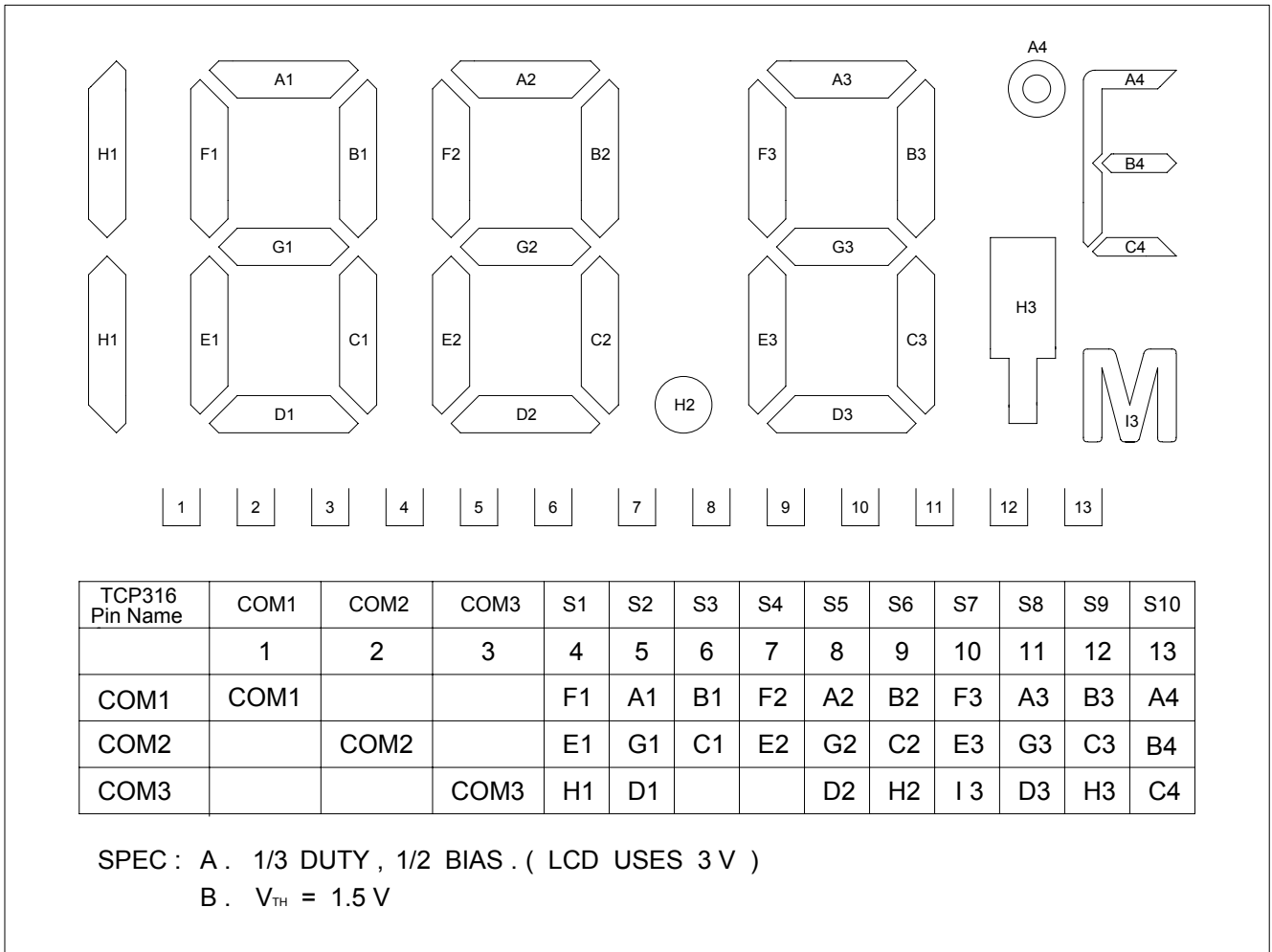

• Application Circuit :

TCP316K-05A/TCP316K-05B Application Circuit

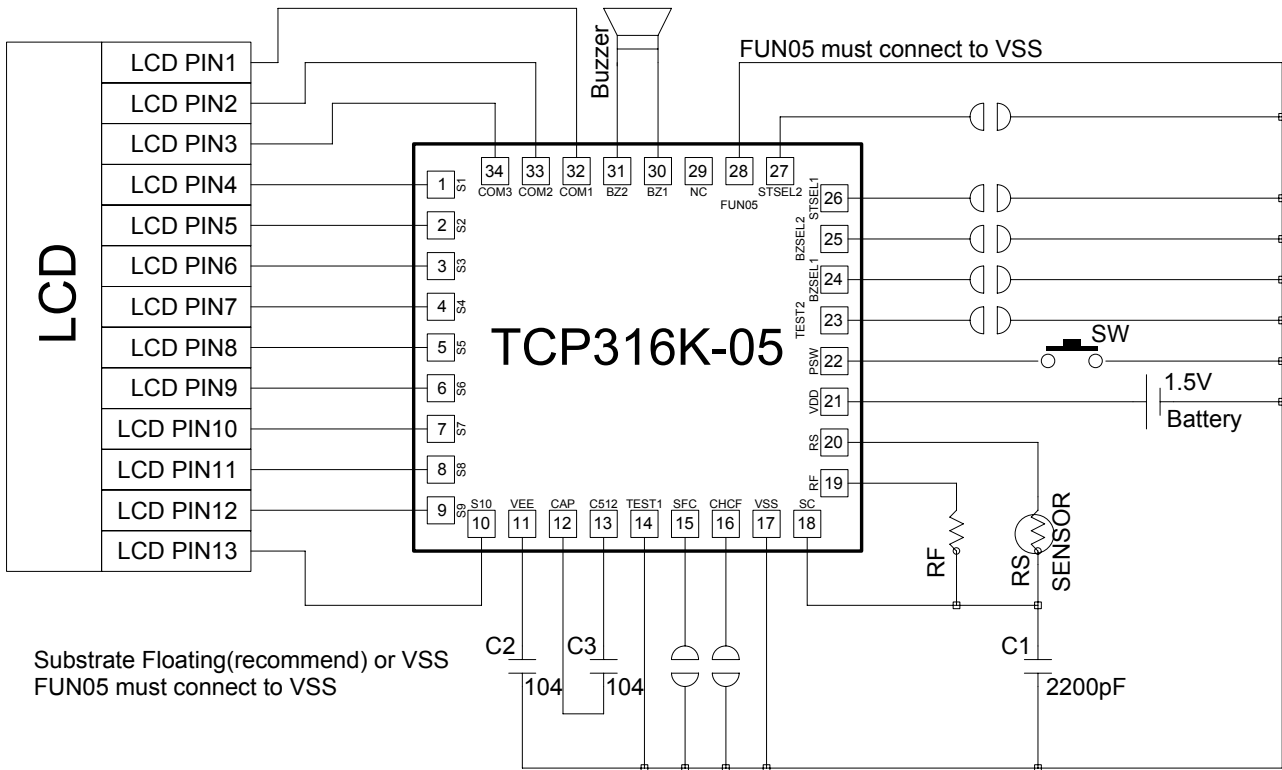

- Remark :
1. Sensor use **503ET** sensor.
 2. RF is selected according to sensor type , RF resistor is the value of sensor **503ET** in **37.0°C**.
 3. About the PCB layout , recommends to do according to following methods.
The space between lines of SC 、RF 、RS and other lines must be large as far as.
 4. Option table :

SFC PAD	°C/°F MODE
VDD or Open	°C Mode
VSS	°F Mode

CHCF PAD	°C/°F MODE
VDD or Open	Not Changeable Mode
VSS	Changeable Mode

Note : At Changeable Mode(CHCF=VSS) , Power ON Initial(**by Battery**) :
Maybe the LCD Display(°C or °F) will be Fail , it must be **Re-Power ON** Initial.

BZSEL1 PAD	BZSEL2 PAD	Buzzer Frequency
VDD or Open	VDD or Open	8.0KHz
VSS	VDD or Open	6.4KHz
VDD or Open	VSS	5.3KHz
VSS	VSS	4.0KHz

STSEL1 PAD	STSEL2 PAD	Stable Time
VDD or Open	VDD or Open	16sec
VSS	VDD or Open	4sec
VDD or Open	VSS	8sec
VSS	VSS	32sec

• PAD Location :

TCP316K-05A/TCP316K-05B PAD'S Diagram

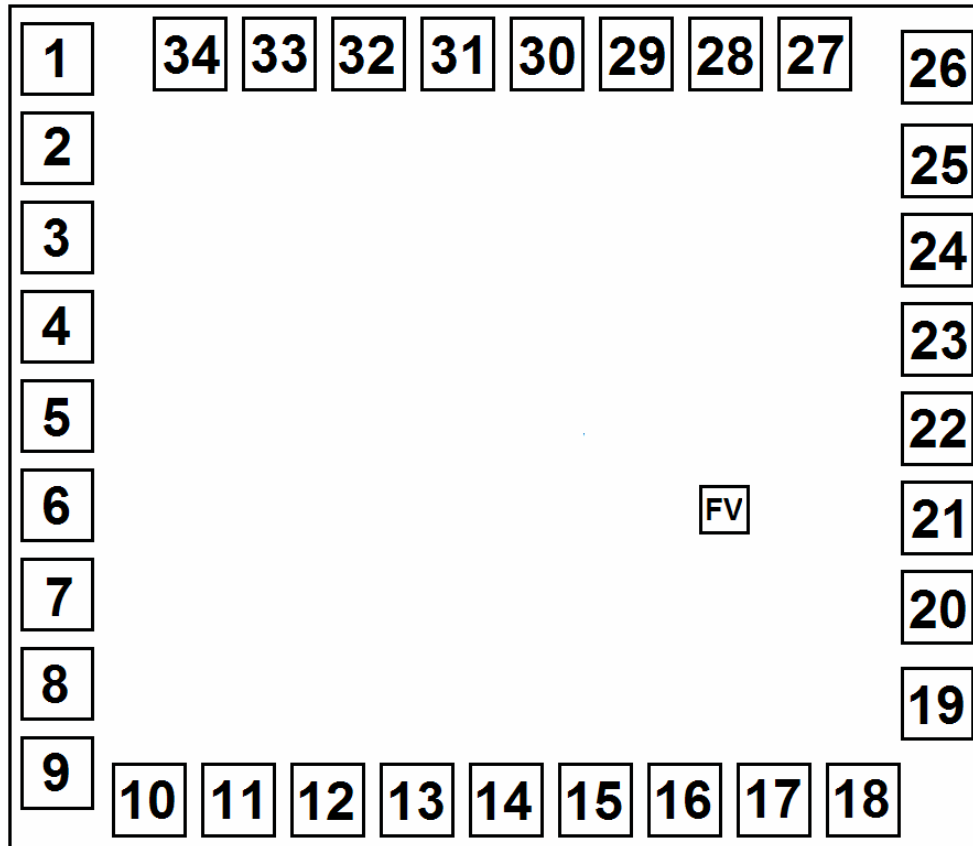

TCP316K-05 Chip Size = 1290um x 1120um

Substrate **Floating**(recommend) or **VSS**

Pad's Coordinate :

Pad No.	Pad Name	X	Y	Pad No.	Pad Name	X	Y
1	S1	-554.850	463.770	18	SC	461.250	-469.980
2	S2	-554.850	351.270	19	RF	554.850	-348.570
3	S3	-554.850	238.770	20	RS	554.850	-227.070
4	S4	-554.850	126.270	21	VDD	554.850	-114.570
5	S5	-554.850	13.770	22	PSW	554.850	-2.070
6	S6	-554.850	-98.730	23	TEST2	554.850	110.430
7	S7	-554.850	-211.230	24	BZSEL1	554.850	222.930
8	S8	-554.850	-323.730	25	BZSEL2	554.850	335.430
9	S9	-554.850	-436.230	26	STSEL1	554.850	453.780
10	S10	-438.750	-469.980	27	STSEL2	399.510	469.980
11	VEE	-326.250	-469.980	28	FUN05	287.010	469.980
12	CAP	-213.750	-469.980	29	NC	174.510	469.980
13	C512	-101.250	-469.980	30	BZ1	62.010	469.980
14	TEST1	11.250	-469.980	31	BZ2	-50.490	469.980
15	SFC	123.750	-469.980	32	COM1	-162.990	469.980
16	CHCF	236.250	-469.980	33	COM2	-275.490	469.980
17	VSS	348.750	-469.980	34	COM3	-387.990	469.980
					FV	295.650	-104.400

Note : Pad Window Size = 90um x 90um , Pad Pitch = 112um

FV-Pad Window Size = 58um x 58um

• Function Flow Chart :

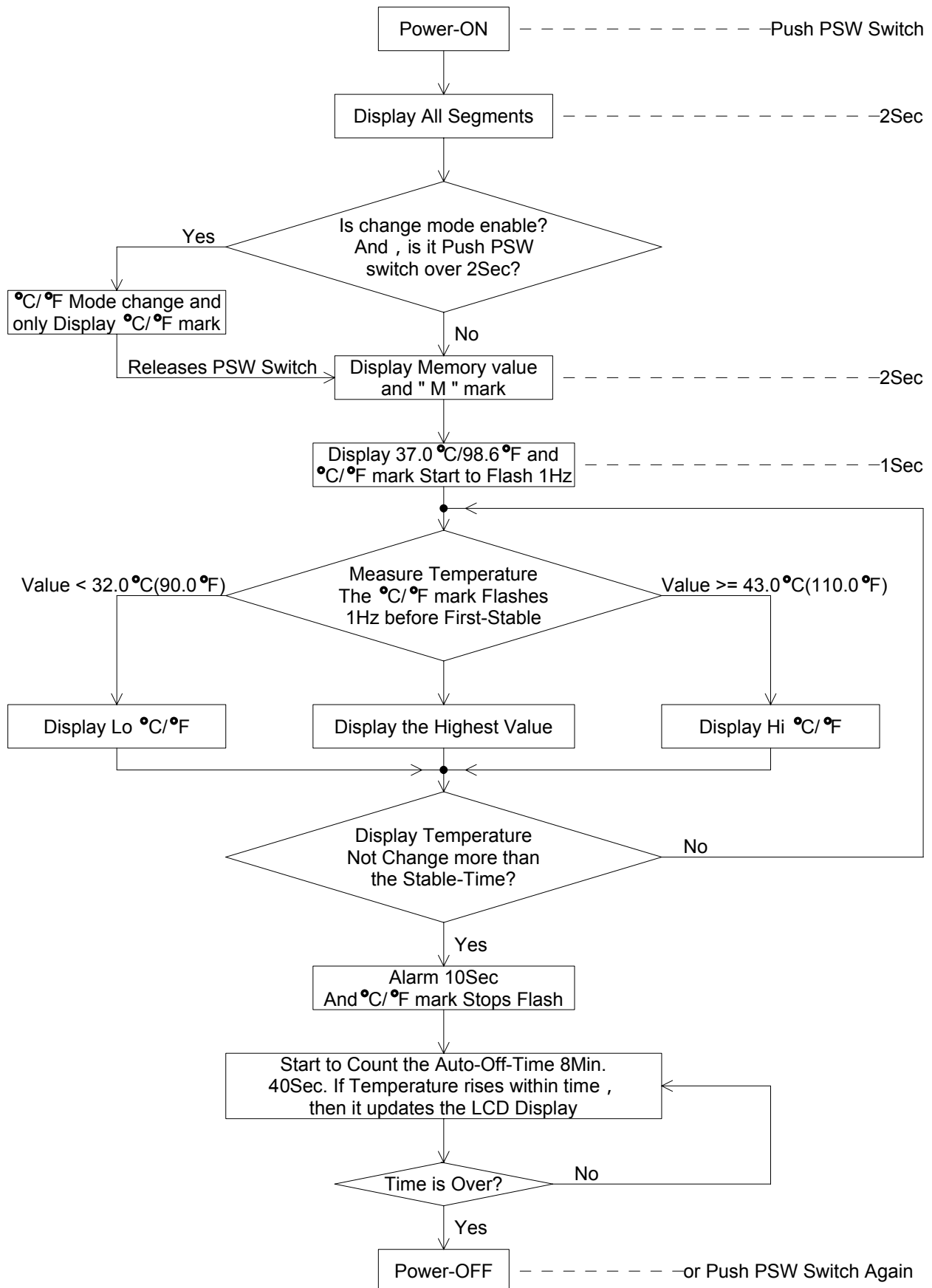

• Order Information :

1. For **TCP316K-05A** :
 - a. Package form : **No support**
 - b. Chip form : TCP316K-05A
 - c. Wafer base : TEP316K-05A
2. For **TCP316K-05B** :
 - a. Package form : **No support**
 - b. Chip form : TCP316K-05B
 - c. Wafer base : TEP316K-05B

• Revision History :

1. 2021/01/27
-Original Version : Ver 1.0
2. 2021/07/08 :
-Modify Version : Ver 1.1
-Delete the repeat describes : Page 07 of 13
3. 2022/05/16 :
-Modify Version : Ver 1.2
-Modify Application Circuit : Page 10 of 13
-Modify Pad Name (OSCIO Modify to **NC**) : Page 4 、 5 、 11 of 13
-Modify Pad Name (TESTF Modify to **FUN05**) : Page 4 、 5 、 11 of 13